

# Analysis of Multi-Path Channels Using the WLAN Packet Preamble

**Alper Akbilek**, Dr. Florian Pfeiffer, Manzar Hussain  
perisens GmbH

## Agenda

1. About perisens
2. Motivation
3. Background
4. Implementation and Results
5. Conclusion

## Agenda

1. About perisens
2. Motivation
3. Background
4. Implementation and Results
5. Conclusion

## About perisens...

### perisens GmbH

Founded in 2009 as Spin-Off from the **Technical University of Munich(TUM)** with ongoing cooperation

#### Services

- Technical Consulting / Studies
- RF measurements & Simulations (up to 90 GHz)
- Development and Evaluation of Wireless Communication Systems
- Signal Processing
- Development of RF Prototypes
- Solutions in Automotive Radar Sensors

#### Products

- In-House Development, Production and Sale of Radar Target Simulators (RTS)



## Agenda

1. About perisens
2. Motivation
3. Background
4. Implementation and Results
5. Conclusion

## Motivation

- Wifi is everywhere
- Higher data rates enabled by new amendments
- High data rates require very favorable channel conditions
- Evaluating the wireless channel is required to determine if implementing new wireless standards (e.g IEEE 802.11ax) would bring improvement

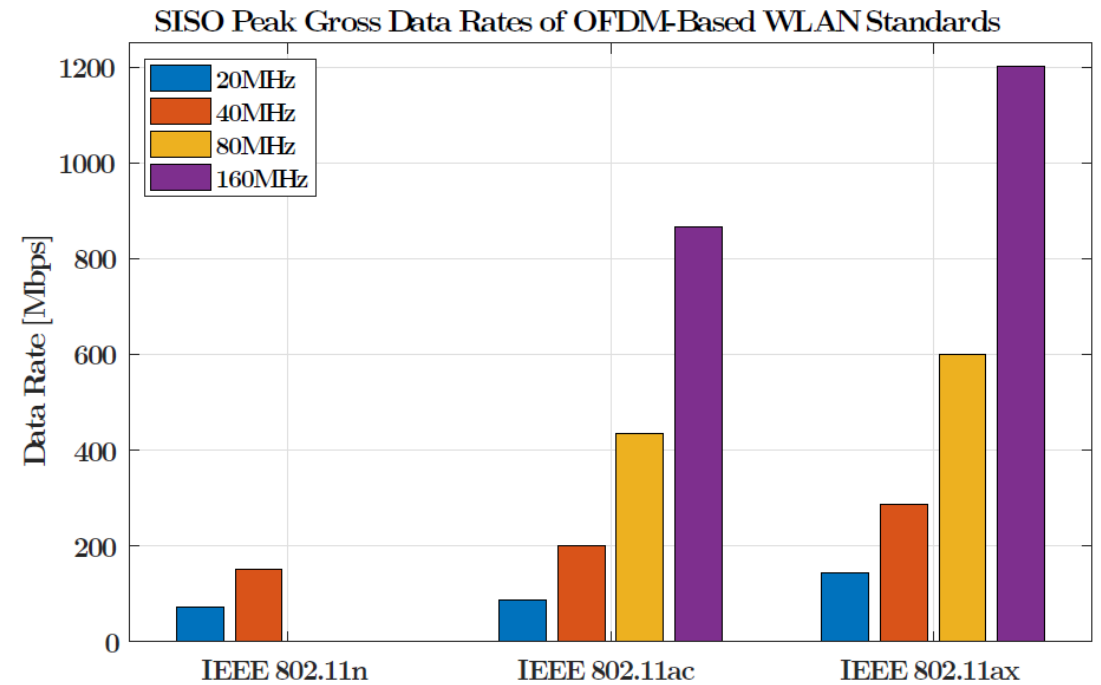

## Goal: Evaluating IEEE 802.11ax (Wi-Fi 6) without Commercial WLAN Hardware

- Matlab models allow evaluation of WLAN standards before commercial hardware hits the market
- We aim to evaluate the standard for specific environment (e.g. in-vehicle environments)
- Simulations and over-the-air testing with Matlab
  - IEEE 802.11ax models are available in MATLAB WLAN Toolbox since 2018

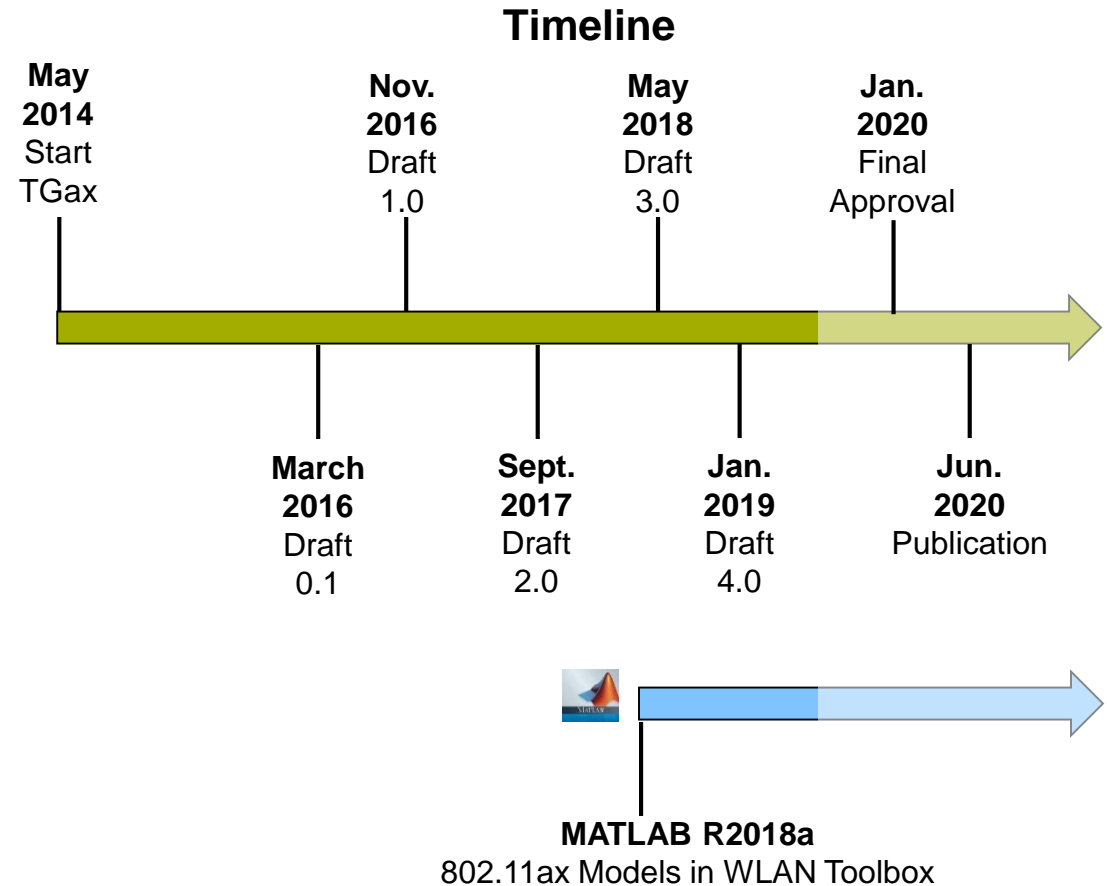

## Agenda

1. About perisens
2. Motivation
3. Background
4. Implementation and Results
5. Conclusion



# OFDM

- Orthogonal frequency-division multiplexing
- Data is transmitted over independent sub-carriers with some redundancy (channel coding)
- Able to cope with severe channel conditions (frequency-selective fading, narrowband interference...)

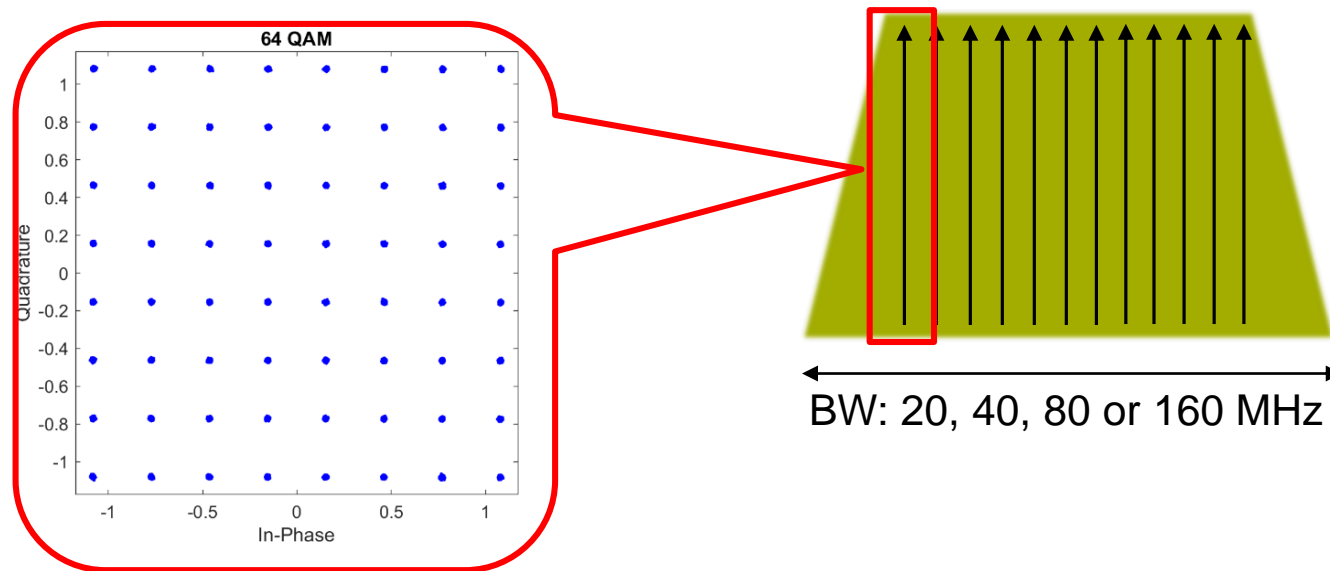

## WLAN sub-carrier distance:

IEEE 802.11a/g/n/ac: 312.5 kHz  
IEEE 802.11ax : 78.125 kHz

# Enabling High Throughput Higher Modulation and Coding Schemes

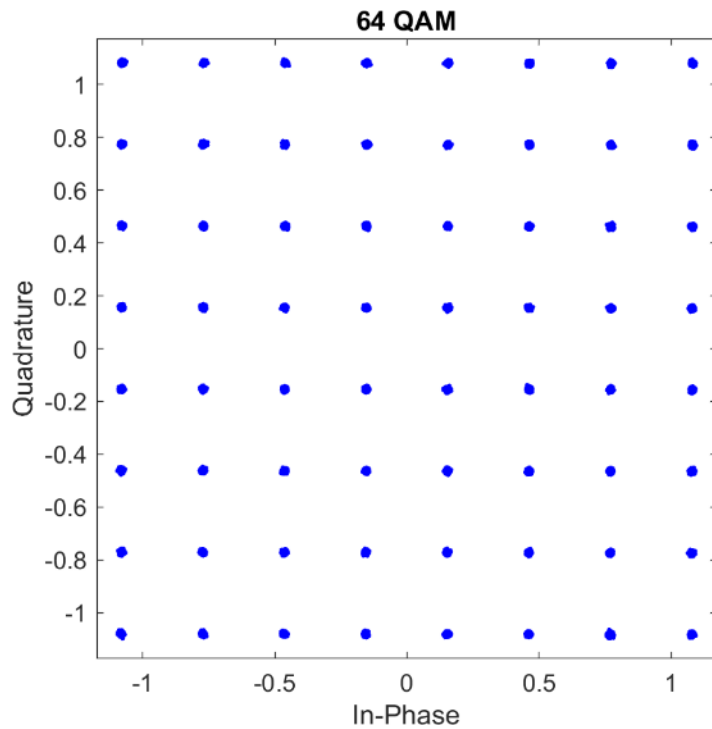

6 Bits/Symbol/Carrier  
MCS 5,6,7  
IEEE 802.11a/g/n

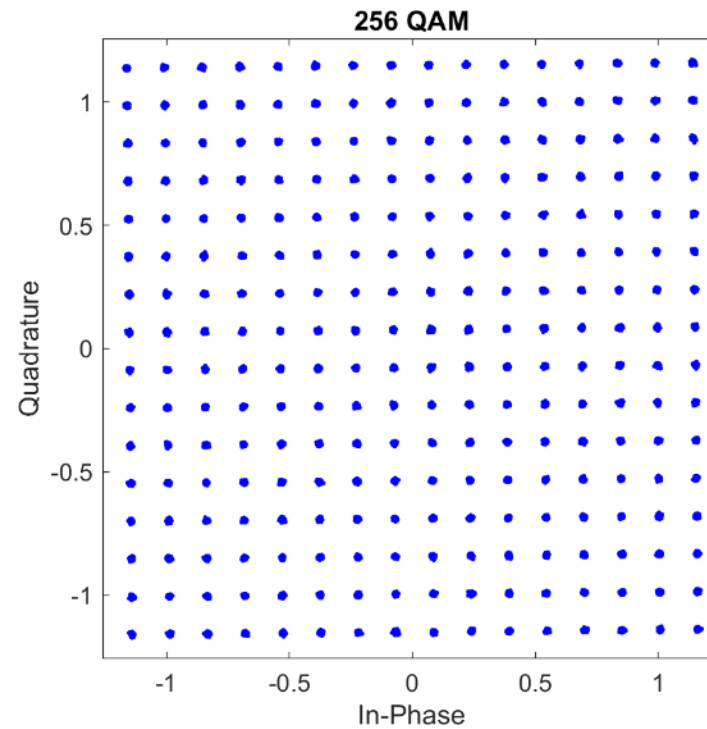

8 Bits/Symbol/Carrier  
MCS 8,9  
IEEE 802.11ac

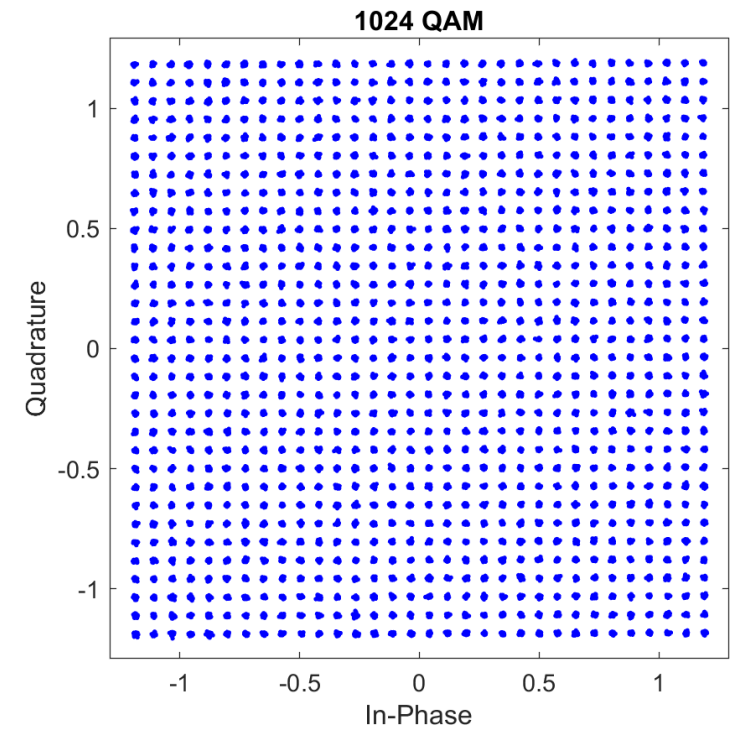

10 Bits/Symbol/Carrier  
MCS 10,11  
IEEE 802.11ax

## Received Signal Strength

- Total received signal power in the channel
- Available at the receiver
- Conventional way to evaluate the link
- High data rates require high signal power at the receiver
  
- **Signal strength is NOT the only factor determining the link speed**

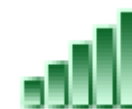
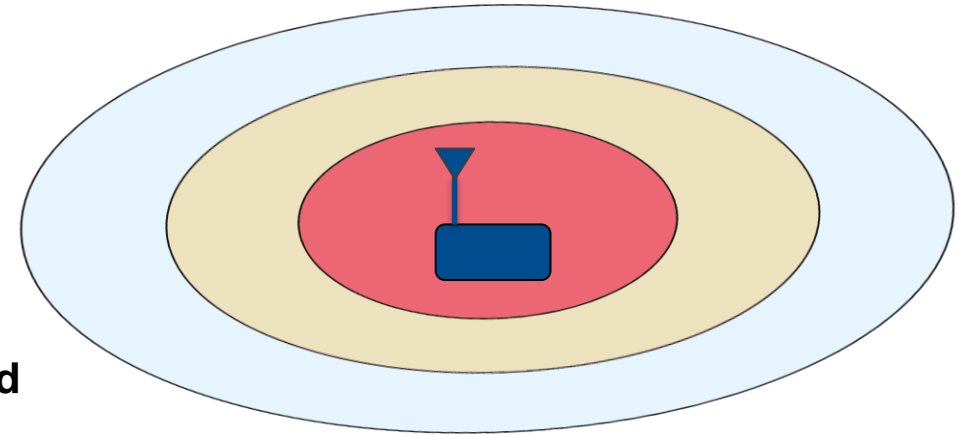

## Multi-Path Channel

- Several echoes of the signal is detected at receiver
- Signal power and SNR are not equally distributed in the channel
- Causes frequency-selective fading which increases the required SNR
- Sensitive to moving objects on the signal path
- Channel models available for IEEE 802.11 simulations

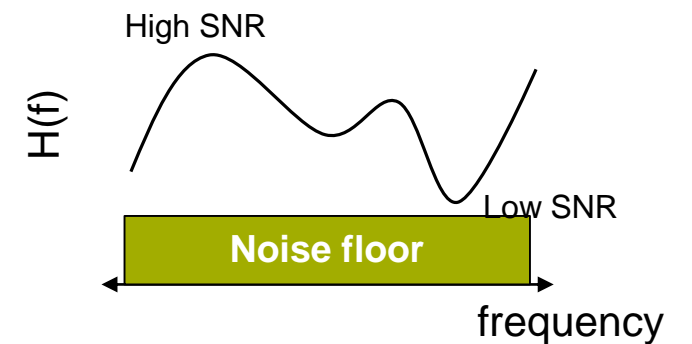
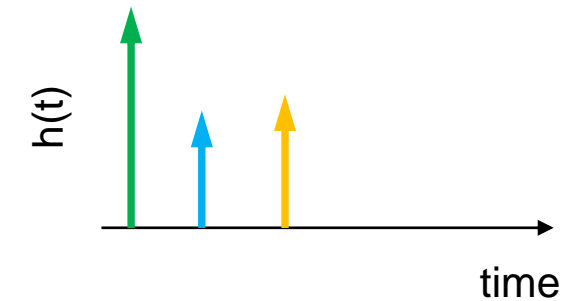
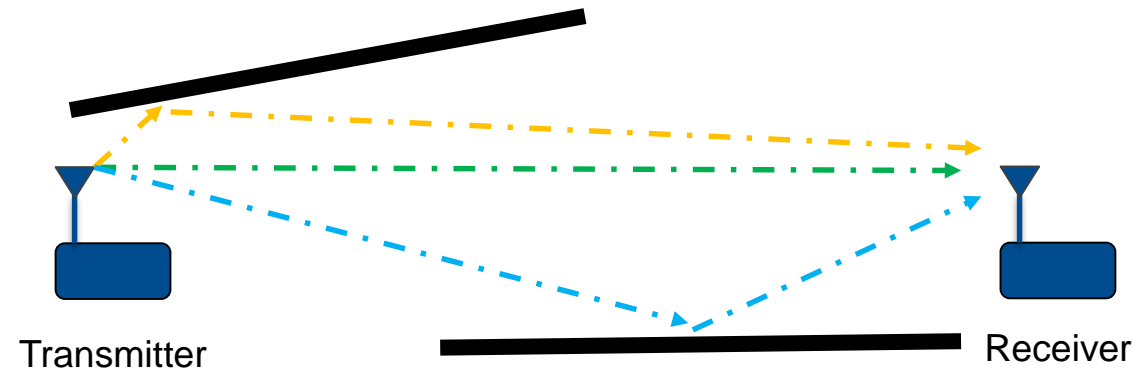

# IEEE 802.11 Packet Preamble

## Channel Estimation by HE-LTF for Equalization

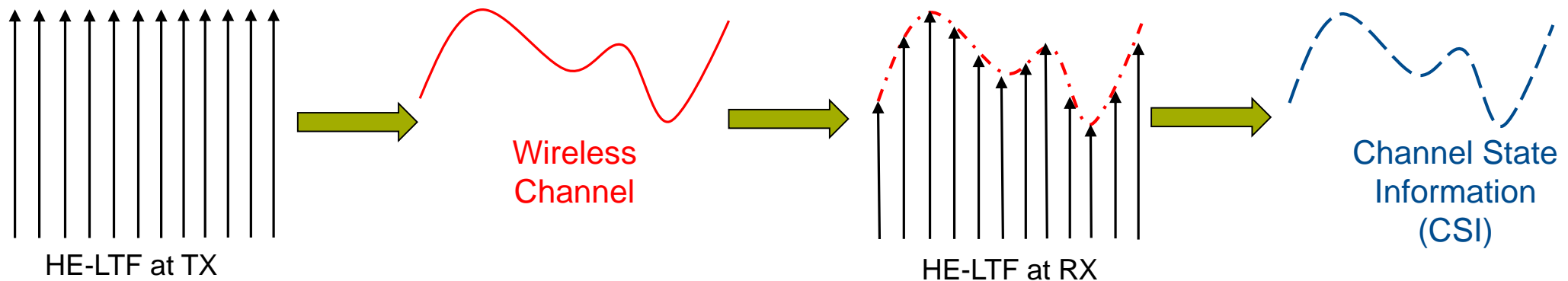
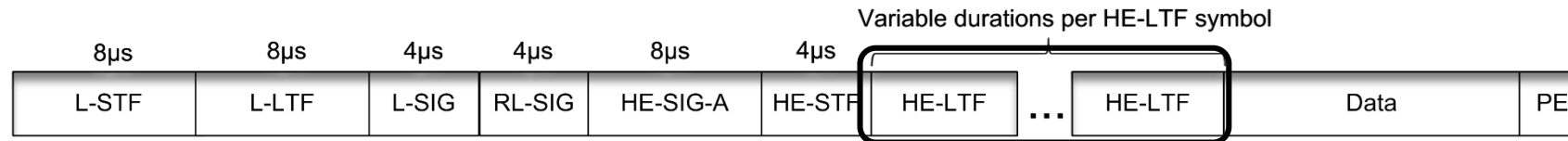

## Agenda

1. About perisens
2. Motivation
3. Background
4. Implementation and Results
5. Conclusion

## WLAN PHY Simulations in MATLAB

- Simulation loop is already included in MATLAB WLAN Toolbox
- IEEE channel models available for example scenarios (small office, conference room etc.)
- Output: SNR requirement for a definite WLAN packet format
- We use simulations for link budget calculations for specific scenarios in which the path loss is known

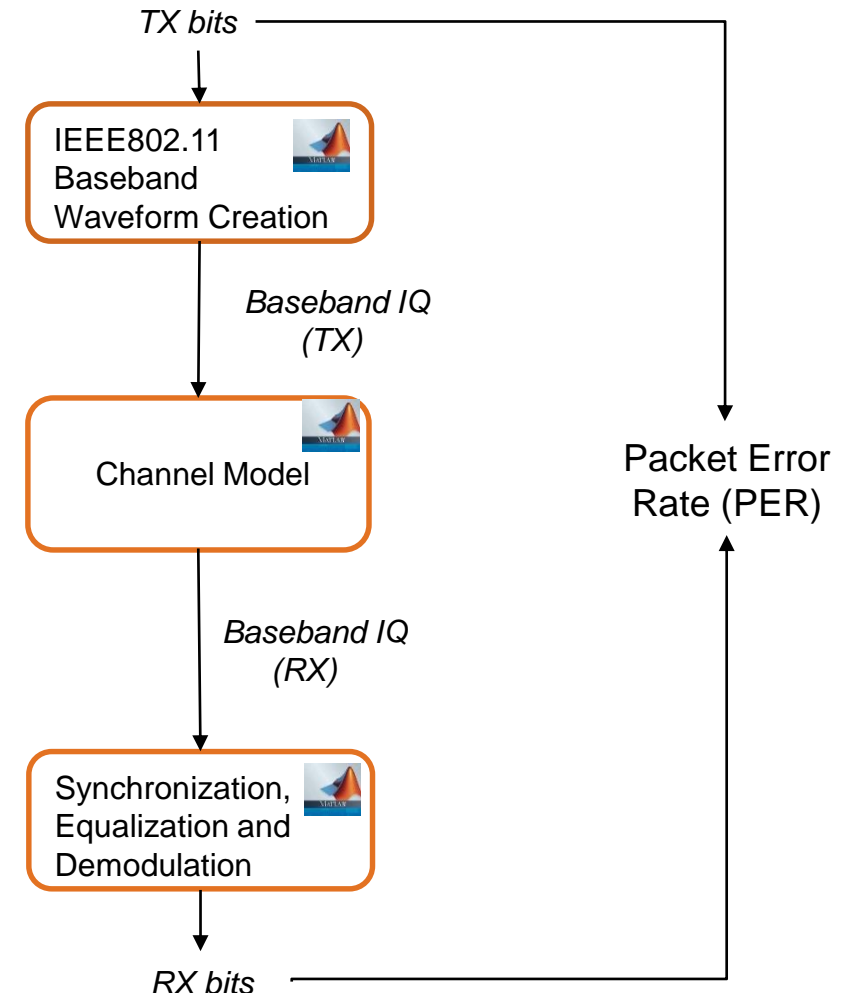

## Opening the Simulation Loop Measurements Over the Air

- Sending WLAN packets over the RF channel
- Evaluate the real wireless channel
- Requires RF instruments or Software-Defined-Radios (SDRs) as TX and RX
- Can measure the PER for a definite packet type
- **Drawback:** Long measurement time

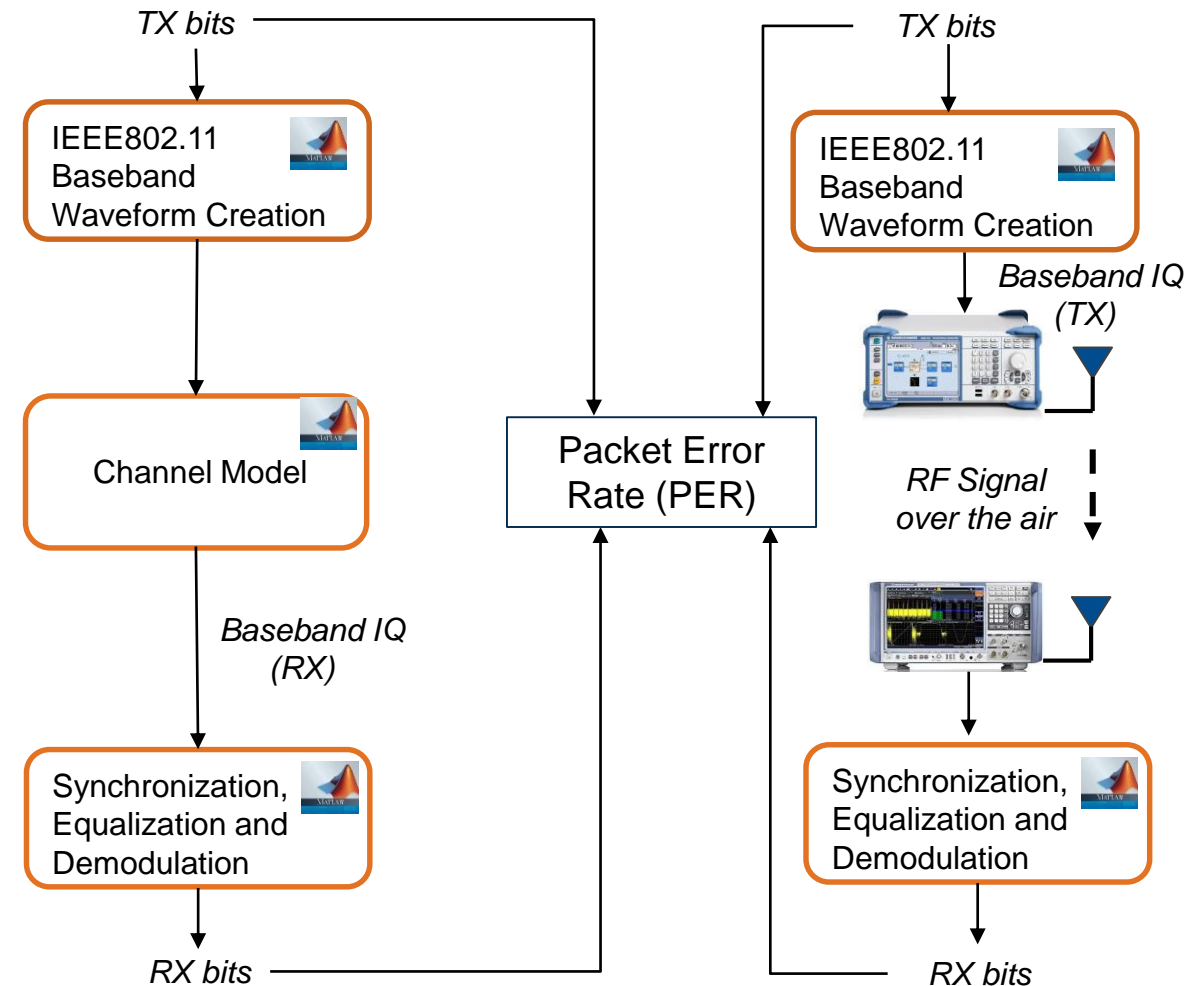



## Channel Sounding

### Extracting the Channel State Information (CSI)

- Instead of making PER measurements, we only extract the Channel State Information (CSI) and signal power
- We collect several CSI samples to use in simulations
- Packet type & modulation are varied in simulations to determine the highest achievable data rates

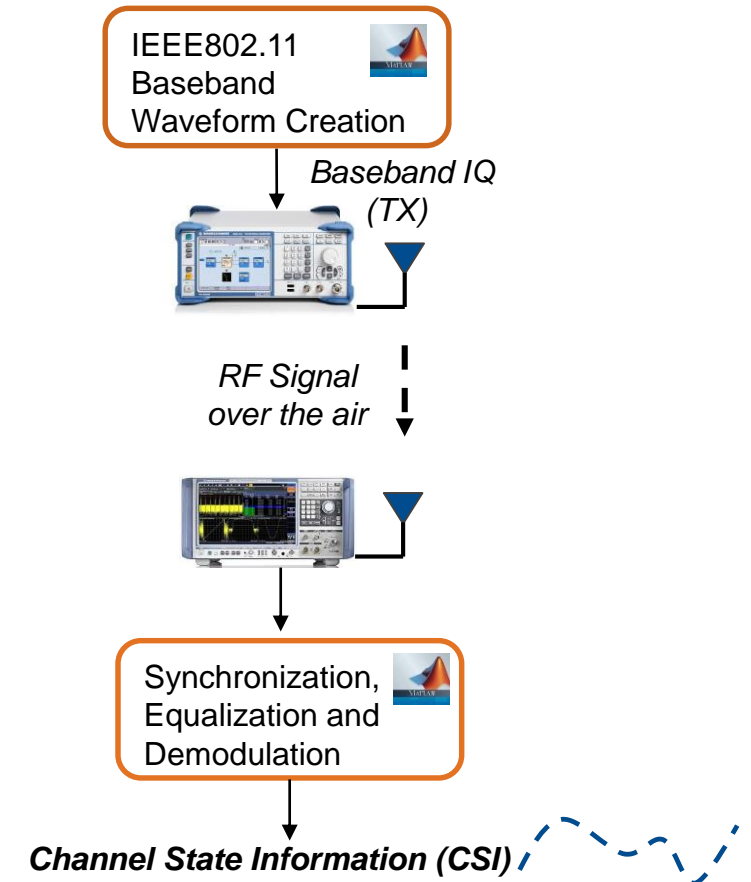

# Channel Sounding Method Using the CSI in Simulations

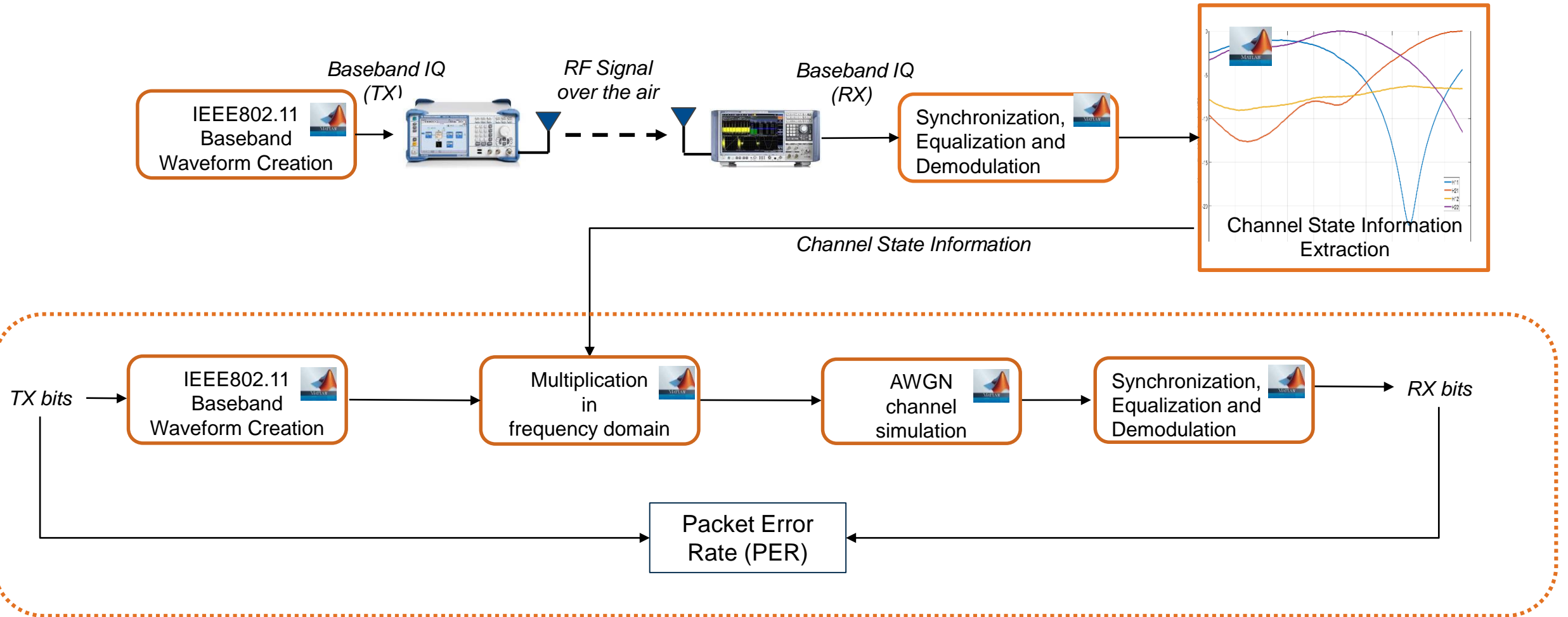

## Channel Frequency Response & Error Vector Magnitude (EVM)

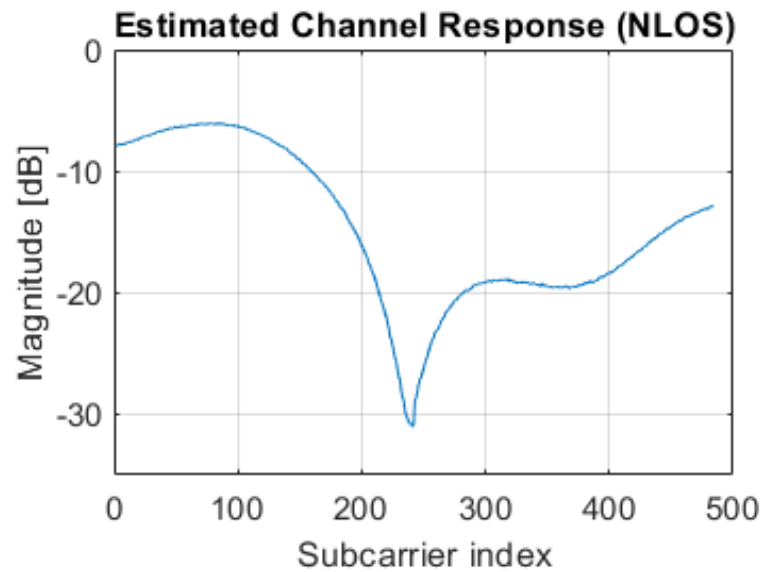

Simulation using  
the measured  
channel response

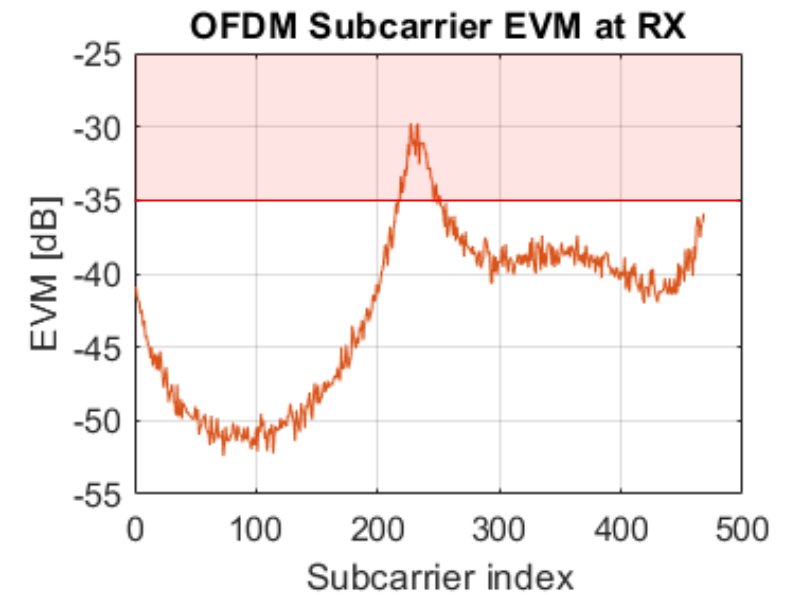

EVM threshold  
for 1024-QAM:  
-35 dB

## Channel Sounding with WLAN Packets Measurement Setup

- Measurement in a closed room
- IEEE 802.11ax waveforms generated in MATLAB
- First transmission with line of sight channel
  - Measured path loss: 53 dB
- Second transmission with non line of sight channel
  - Measured path loss: 59 dB

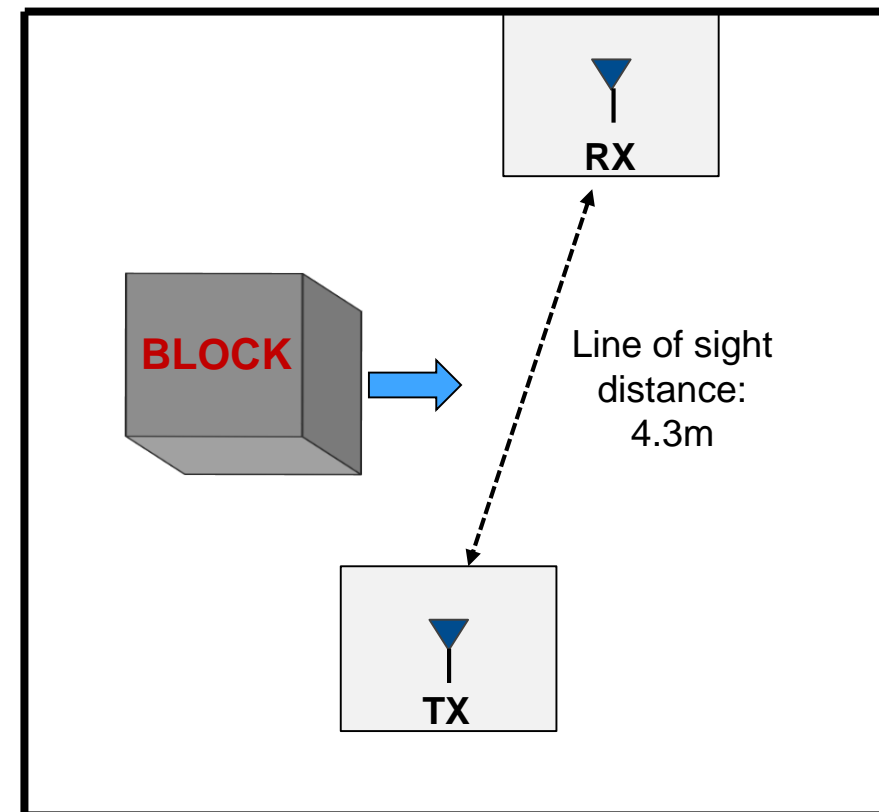

## Channel Sounding with WLAN Packets Measurement Setup

- Measurement in a closed room
- IEEE 802.11ax waveforms generated in MATLAB
- First transmission with line of sight channel
  - Measured path loss: 53 dB
- Second transmission with non line of sight channel
  - Measured path loss: 59 dB

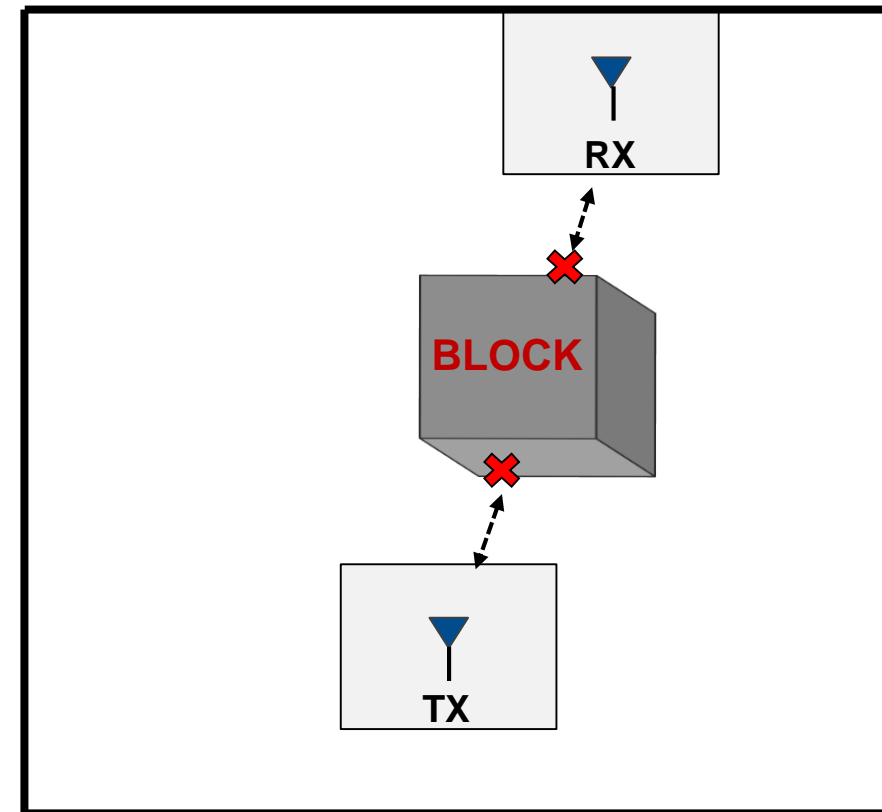

# Channel Sounding with WLAN Packets

## Results

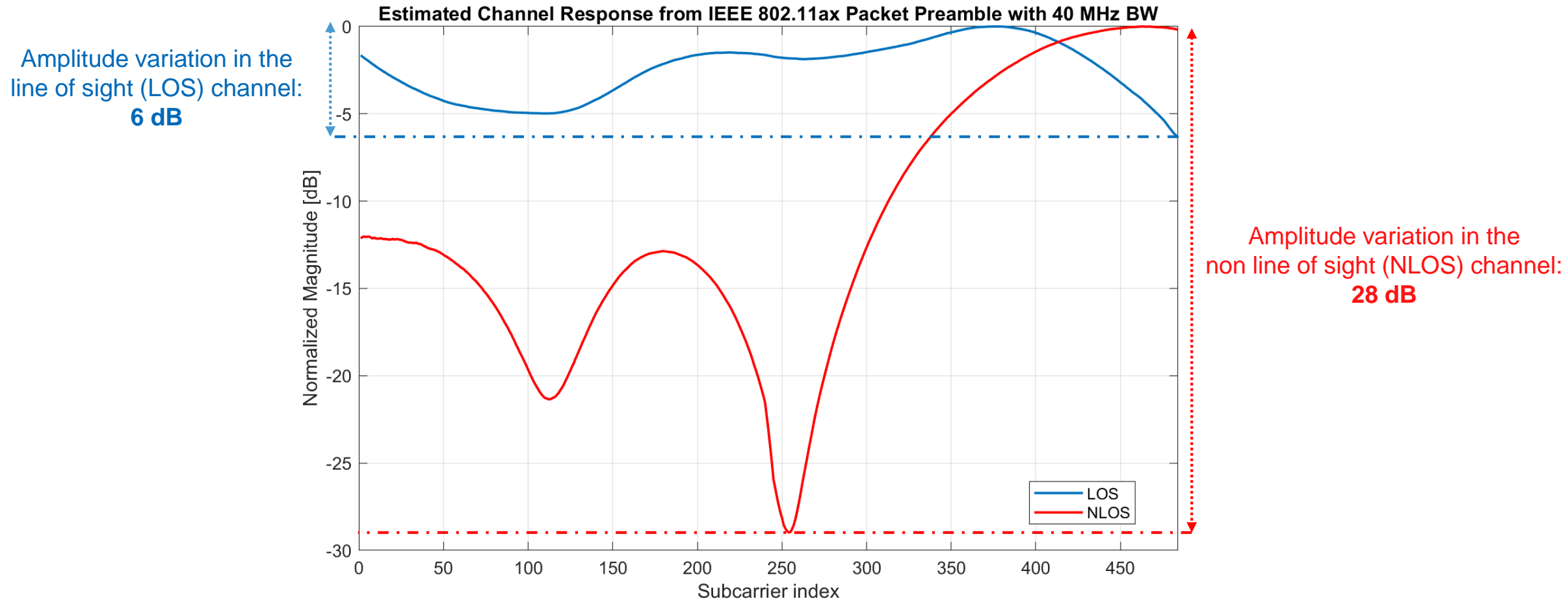

# Simulation Using the LoS and NLoS Channel Responses Results

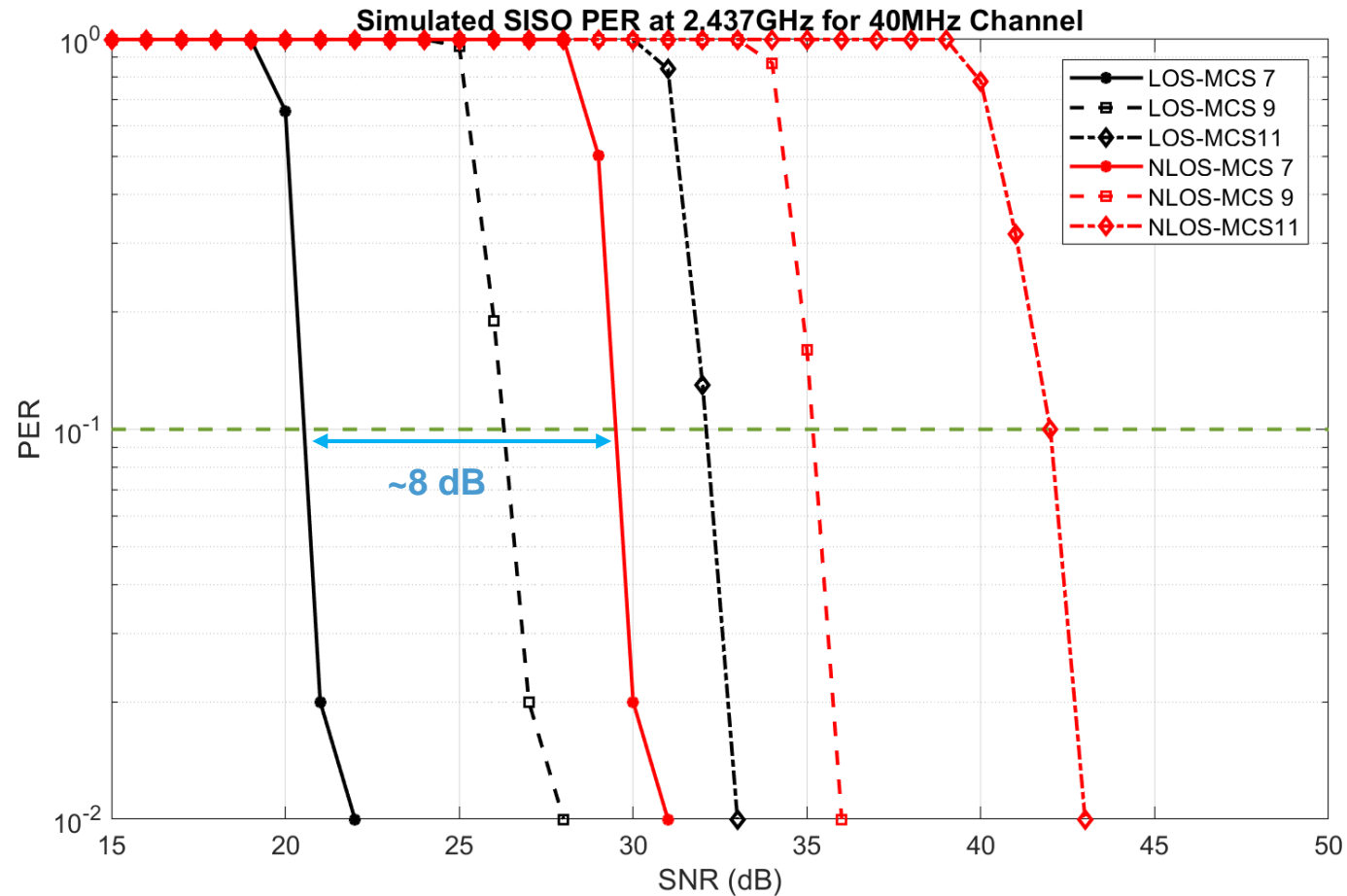

## Agenda

1. About perisens
2. Motivation
3. Background
4. Implementation and Results
5. Conclusion



## Conclusion

### Summary

- New wireless standards can be evaluated with MATLAB before the hardware hits the market
- Wireless channels can be analyzed using the WLAN signals
- Energy is not evenly distributed in a non line of sight (NLOS) channel
- Receiver needs higher signal power to decode the signal in NLOS scenarios
- The channel state information (CSI) changes if there are moving objects in the room

### Future Work

- Other applications using the channel state information (CSI) of WLAN signals:
  - Human presence detection
  - Vital signal monitoring (breathing & heart rate)